



First Photo of George & Rita Phelps' New 1967 I-H Travelall, Jan. 1968

## THE INTERNATIONAL TRAVELALL



1967 International Travelall 2006

INTERNATIONAL®



1100 B 4x4

G. Phelps

RATING

EMPTY (Full tanks & tools aboard) on 11/14/96 weighed 5628 lbs
MAXIMUM GROSS VEHICLE WEIGHT..... 5,600 lbs.

STANDARD EQUIPMENT

AXLE, FRONT

FA-16 2,800-lb capacity driving
Hypoid single-reduction, 8 1/2" ring gear
Ratios: 4.09 or 4.77 to 1

AXLE, REAR

RA-18 3,500-lb capacity
Hypoid single-reduction, 8 1/2" ring gear
Semi-floating, induction-hardened flanged shafts
Ratios: 4.09 or 4.77 to 1

BRAKE, PARKING

Mechanical control of rear service brakes
Foot-pedal applied, finger-lever released
Total lining area, 90.8 sq. inches

BRAKES, SERVICE

Self-adjusting hydraulic, dual operation with warning-light
Single-cylinder, single-piston front,
Single-cylinder, double-piston rear
Size: 12 x 2" front, 12 x 1 3/4" rear
Total lining area: 188.6 sq. inches

CAB

All steel, with safety glass windows and sweep-around windshield
Door locks both sides with safety latches
Non-glare padded instrument panel with ammeter, fuel, water temperature and oil pressure gauges
Full-width adjustable seat, with Torflex spring construction, vinyl upholstery and polyurethane foam cushion
Acoustical roof headliner

CAB (Continued)

Rubber floor mat, with sound deadening insulation
Padded sun visor for driver
Ash tray; hand choke
Two-speed non-glare electric windshield wipers and electric washers
Seat belts and shoulder harness anchors
Chrome door-mounted and inside rear view mirrors

CLUTCH

10-inch 9-spring single-plate
Hydraulic control; vibration dampener

COOLING SYSTEM

18.5 quart system capacity
Radiator frontal area: 497 sq. inches

ELECTRICAL SYSTEM

12-volt, 37-amp alternator
50 amp-hr, 54-plate battery
Fuse panel in glove compartment
Dual stop and tail lights
Dome light; single electric horn
Directional signals: front in parking lights, rear in stop lights
Hazard switch

ENGINE

International BG-241 gasoline six
Gross BHP: 140.8 @ 3,800 rpm
Gross torque: 223.5 lb/ft @ 2,000 rpm
241 cu. in. displmt; 7.5 to 1 compr. ratio
Oil bath air cleaner; full-flow oil filter

FINISH

Chassis: black; bumper: white
Hood, cab, fenders and wheels: choice of any standard IH color

FRAME

Pressed steel channel main rails
119"-131" WB: 6 1/16 x 2 3/16 x 0.150"; 3.99 sec. mod
140" WB: 7 x 3 x 0.179"; 4.80 sec. mod.
Formed-channel front bumper

FUEL TANK

19-gallon, mounted under cab

STEERING

S-9 gear, with 17-inch steering wheel

SUSPENSION

Semi-elliptic steel leaf springs
Front: 2 1/2 x 42"; 2,720-lb capacity
Rear: 2 1/2 x 52"; 2,760-lb capacity
Front and rear shock absorbers

TRANSFER CASE

TC-141 two-speed constant-mesh
Single control lever selects high or low range and front axle declutch; permits low range operation in 4-wheel-drive only
Ratios: 1.93 and 1.00 to 1
Provision for full-torque PTO

TRANSMISSION

4 speed synchro
T-4 three-speed synchromesh, direct
Gearshift lever on steering column
Ratios: 3.03, 1.64, 1.00; 3.68 rev.

WHEELS and TIRES

Single front and rear, with spare
8.15 x 15, 4-PR tubeless tires
5-stud disc wheels, with 5.50K rims
5 1/2" bolt circles

OPTIONAL EQUIPMENT

AXLE FRONT

Warn locking hubs. Tie rod guard

AXLE REAR

RA-28 3,500-lb single-reduction with Powr-Lok limited-slip differential
Ratios: 4.09 or 4.77 to 1
RA-53 3,700-lb single reduction
Ratios: 3.54, 4.10, 4.56
Ra-54 3,700 lb. capacity single reduction
With Powr-Lok limited-slip differential
Ratios: 3.54, 4.10, 4.56

BODIES

7-ft or 8 1/2-ft. regular pickup, with underslung tire carrier and backup lights
7-ft or 8-ft Bonus-Load pickup, with inner-body tire carrier and backup lights

BODIES (Continued)

Travelall® body, with 4 side doors, rear tailgate with electrically-operated roll-down window, white rear bumper, inner-body tire carrier, dual padded sun visors and back-up lights.

Optional: full-width fold-down center seat; removable rear seat; no panel doors at rear; trim packages

Panel body, with 4 side doors, double rear doors, individual bucket driver's seat, white rear bumper, inner-body tire carrier and back-up lights

8-ft stake body
6-ft Bonus-Load pickup with inner-body tire carrier and back-up lights for Travelette cab

BRAKES, SERVICE

Vacuum power assist system

CAB

Deluxe interior package
Custom interior trim package
Exterior trim package
Laminated, clear glass windows in lieu of tempered
4-door, 6-passenger Travelette cab
Full-width or passenger seat (for panel body)
Tinted glass
Arm rest, left or right side
Glove box lock
Chrome door-mounted passenger side mirror
Right outside mirror

Illustration May Include Optional Equipment

**OPTIONAL EQUIPMENT (Continued)**

**CAB (Continued)**

Fresh air or recirculating heater  
 Super-capacity heater and defroster

**CLUTCH** *Factory A-C*

11-inch 9-spring  
 11-inch 12-spring  
 12-inch 12-spring

**COOLING SYSTEM**

Increased capacity system  
 Permanent anti-freeze: -20°F

**ELECTRICAL SYSTEM**

52- or 61-amp alternator. Dual electric horns  
 60 or 70 amp-hr battery  
 Front axle warning light  
 Two cab corner marker lights  
 Three front cab marker lights  
 Cigar lighter  
 Radio and antenna  
 Camper electrical connector

**ENGINE**

BG-265 153.5-BHP gasoline six  
 V-266 154.8-BHP gasoline V8  
 V-304 193.1-BHP gasoline V8  
 V-345 gasoline V8  
 Automatic choke  
 High altitude equipment  
 Velocity-type engine governors  
 Hand throttle control

*Net 182hp @ 3800  
 Gross 197hp @ 4400*

**FRAME**

Underslung tire carrier; carrier lock  
 Left side tire carrier, for regular pickup  
 Chrome bumpers, front and rear  
 White rear bumper  
 Two front tow hooks

**FUEL TANK**

*18-gal right side*  
 Auxiliary 14-gallon under left side, with dash-mounted tank selector

**FUEL TANK (Continued)**

15-gallon under cab, in lieu of standard

**STEERING**

Hydraulic power assist system *no*

**SUSPENSION**

3,120-lb heavy-duty front springs  
 4,420-lb heavy-duty rear springs  
 5,520-lb auxiliary rear springs *no*

**TRANSMISSION**

T-7 HD 3-speed direct Synchronesh with floor-mounted control lever  
 T-16 four-speed synchronesh, direct  
 T-28 3-speed automatic  
 T-34 HD 5-speed, overdrive  
 T-36 HD 5-speed, direct  
 Transmission-mounted PTO *no*  
 Full-torque PTO for transfer case *no*  
 Front-mounted winch, cable and hook *no*  
 Oil cooler for T-28

**WHEELS AND TIRES**

Optional tire sizes as shown below  
 Chrome hub caps, front and rear

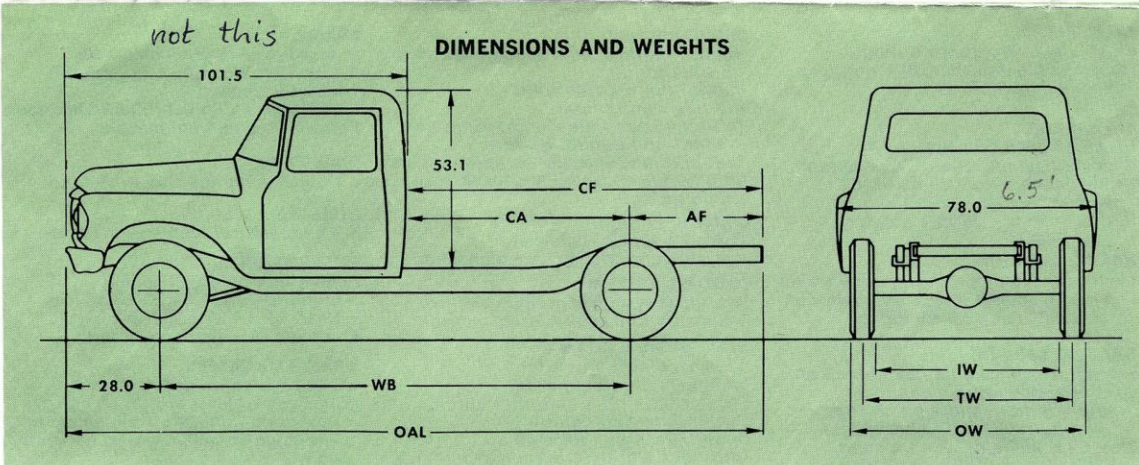

DIMENSIONS COMMON TO ALL WHEELBASES, with 8.15 x 15 TIRES			
Overall Width: 78" at front fenders	Ground Clearance: 7.3" at front axle	Frame Height at Rear Axle: 29.2" empty	
Overall Height: 71.9" at top of cab	7.3" at rear axle	25.8" loaded	

CHASSIS DIMENSIONS and WEIGHTS									
WB	CHASSIS WEIGHTS, LBS.*			DIMENSIONS				TURNING RADIUS	
	Front	Rear	Total	CA	CF	AF	OAL	To Centerline of Tire	With Bumper Clearance
119"	2,370	1,115	3,485	45½"	85¼"	39¾"	186¾"	23 ft. 4 in.	24 ft. 7 in.
131"	2,385	1,125	3,510	57½"	103¼"	45¾"	204¾"	25 ft. 6 in.	26 ft. 8 in.
140"***	2,555	1,380	3,935	33½"	73¼"	39¾"	208¾"	27 ft. 1 in.	28 ft. 3 in.

\*With regular cab, standard equipment and tires, oil, fuel and water.  
 \*\*With Travelette cab, standard equipment and tires, oil, fuel and water.

**TIRE DIMENSIONS**

Tire Size	TUBELESS on DISC WHEELS			TIRES and TUBES on DISC WHEELS		
	8.15x15	8.45x15	6.50x16	7.00x15	7.00x15	9.00x15
Rim Size	5.50K	6.00L	5.00K	5.50F	6.00L	5.50F
Outside width OW	69.4"	69.8"	68.5"	69.5"	69.5"	70.8"
Tread TW	61.4"	61.5"	61.6"	61.8"	61.3"	61.3"
Inside width IW	55.0"	53.1"	55.3"	53.4"	53.5"	51.9"
Chain clearance	6.4"	5.4"	6.6"	5.6"	5.6"	4.8"
Front Tread	64.8"	64.9"	64.4"	64.8"	64.3"	64.8"

In order that product improvements may be introduced at any time, specifications are subject to change without notice.

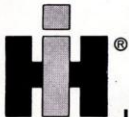

INTERNATIONAL HARVESTER COMPANY • 401 NORTH MICHIGAN AVE. • CHICAGO, ILLINOIS 60611

CT-400-E. AD-4458-T-6. 2-1.

ORDER AD SPEC. SHEETS ON AD-4130.

Litho in United States of America

# LINE SETTING TICKET

DATE BUILT	DATE SHIPPED	05/29	MOTOR TRUCK DIVISION	168.00	LINE SEQUENCE NO. 2
VIA	FRT. PPD.	DISTRICT	ORD. QTY.	LINE SET DATE	ORDER NO.
BI LEVEL NYC	YES	OAKLAND	725	1	621 509S E
SHIP TO				*****	
IHC 1000 GLENDALE ROAD P O BOX 1450 SPARKS NEVADA 89431 RAILHEAD SPARKS				783107	
				CHASSIS SER.	

7831073	0000	1	1100B 4X4	119 05600 A	7831073	897
01000	0901	3ADKN	FRAME AND BUMPER			
01544	0015		TUBULAR TIRE CARR U/S			
02016	0002	A	FA-16 FRONT AXLE	4.09		
02915	0010		FRT AXLE LOCKING HUBS			1
02930	0003		TIE ROD PROTECTOR			1
03005	0001		HD FRT SPRING			12
03124	0002		HD RR SPRINGL AUX			12
04001	0083	3DE	HYDRAULIC BRAKES			
04007	0035	AN	PARKING BRAKE			15
04106	0003		FRONT BRAKE GROUP			16
04203	0003		REAR BRAKE GROUP			17
05009	0004	AE	S-13D STEERING GEAR			18
06100	0023		DRIVE LINE MOUNTING			19
231521	7134		PROPELLER SHAFT	1		20
231521	7370		PROPELLER SHAFT	3		21
231521	7410		PROPELLER SHAFT	5		22
07000	0555	3AD	EXHAUST SYSTEM			23
08000	2110	CHNZ	WIRING SYSTEM			24
08052	0052	D	12V 60A INC CAP BATTERY			26
08512	0010		FRONT AXLE WARNING LIGHT			27
08583	0232	A	SHEET METAL			28
09000	0680	BEQW	SPEEDO-TOOLS-MISC			29
10000	0486	ADG	12 IN 12 SPG CLUTCH			30
11123	0016	ACF	V 345 GAS ENGINE			31
12110	0100	AFHNS	INCREASED COOLING			32
12740	0337		IHC PERM ANTI FREEZE			33
12761	0005	C	T 16 TRANSMISSION			34
13016	0064	BD	T141 TRANSFER CASE			35
13141	0025	DEK	RA28 SR AXLE PWR LK 4.09			36
14028	0003	GKNQ	14 GAL AUX TANK W/UC TK			37
15214	0006	BF	TRANS COVER/FLOOR MAT			38
16000	0142	B	TRAVELALL W/TAILGATE			39
16156	0011	FGKLV	DELUXE INTERIOR TRIM			40
16634	0013	CDEHTVY	SUPER CAP HEATER / DEF			41
16655	0009	B	INTERMEDIATE FOLD SEAT			42
16820	0006	A	EXTERIOR TRIM PKG			43
16835	0002	BG	FT DISC WHL 15X550F			44
18530	0057		845x 700x 15 6PR TT FT DC 550F			45
185307	0000		SGI RR DISC WH 15X550F			46
22530	0056	EQ	700X15 6PR TT SR DC 550F			47
225307	0000		700X15 6PR TT SPARE TIRE			48
245106	0000		STANDARD TWO TONE			49
10772	0007		PAINT ROOF PANEL			50
			9120 WHITE			51
2 0202			PAINT BAL BODY			52
			HOOD FENDERS GRILLE			53
			5688 GREEN			54
			409SPEC			55

SYSTEM MASTER ADDRESSOGRAPH-MULTIGRAPH CORPORATION - PRINTED BY THE STANDARD REGISTER COMPANY, U. S. A. 9-66

IS 61 T

538278

**CONDITIONAL SALE CONTRACT  
FOR NEW INTERNATIONAL OR USED  
MOTOR VEHICLES AND ATTACHMENTS**



DATE **November 24, 1967** CONTRACT NO. \_\_\_\_\_  
PURCHASER (FIRM NAME) **George A. or Rita Phelps**  
ADDRESS **2091 Holman**  
CITY **Sparks** COUNTY **Washoe**  
STATE AND ZIP CODE **Nevada 89431** PHONE **358-4069**

SELLER **International Harvester Co.**  
CITY AND STATE **Sparks, Nevada 89431**

Purchaser hereby purchases, and seller hereby sells, subject to all terms, conditions and agreements contained herein, including the ADDITIONAL PROVISIONS printed on the reverse side hereof, the following described property, delivery, inspection and acceptance of which are hereby acknowledged by purchaser:

CHECK ONE	CHASSIS			TIRE SIZE						WHEELS	RATED TONS	CAPACITY MAXIMUM LBS. INCLD.G. BODY & LOAD	NO.	PAINT COLOR
	QU.	YEAR-MODEL*	W.B.	CAB	FRONT			REAR						
<input checked="" type="checkbox"/> NEW		<b>1967</b>	<b>119</b>		RIM	SIZE	PLY	RIM	SIZE	PLY	TYPE	CAST DISC		<b>White Green</b>
<input type="checkbox"/> USED	<b>1</b>	<b>1100BTA</b>	<b>4X4</b>		<b>845X15</b>	<b>4</b>		<b>845X15</b>	<b>8</b>		SINGLE DUALS			

\* YEAR DESIGNATED IS THE YEAR FOR WHICH THE VEHICLE IS FIRST TITLED UNDER PROCEDURES ESTABLISHED BY THE MANUFACTURER.

GEAR RATIO	CHASSIS NO.	ENGINE NO.	IDENTIFICATION NO.	BODY - TYPE AND COLOR
<b>4.09</b>	<b>783107H73599D</b>	<b>520135</b>	<b>783107H35990</b>	<b>Travelall 1100B 4X4 White &amp; Green</b>

OTHER EQUIPMENT  
**Tire Carrier, Locking Hubs, Tie Rod Guard, H.D. Front & Rear Springs, 60 AMP Battery, Warning Light, 12" Clutch, V-345 Engine, Increased Cooling, 4Spd Trans, Power-Lok R Axle, Dual Fuel Tanks, Deluxe Int Trim, Sec. Seat Heat & Defroster, Super Capacity, Exterior Trim.**

MAKE	YEAR-MODEL	CHASSIS NO.	ENGINE NO.	BODY TYPE	ALLOWANCE	AMT. OWING (IF ANY)	NET TRADE-IN ALLOWANCE
		<b>NONE</b>			\$	\$	\$

CASH SALE PRICE	<b>4,018.00</b>
ADD SALES OR USE TAX	<b>120.54</b>
<b>1. TOTAL CASH SALE PRICE</b>	<b>4,138.54</b>
<b>2. DOWN PAYMENT:</b>	
CASH	<b>1,138.54</b>
NET TRADE-IN ALLOWANCE	<b>XXXX XX</b>
<b>TOTAL DOWN PAYMENT</b>	<b>1,138.54</b>
<b>3. UNPAID CASH BALANCE (1 LESS 2)</b>	<b>3,000.00</b>
<b>4. OTHER CHARGES DESCRIBE:</b>	
<b>5. COST OF PHYSICAL DAMAGE INSURANCE</b>	
<b>5-A SUB TOTAL</b>	<b>3,000.00</b>
<b>6. COST OF GROUP CREDITOR LIFE INSURANCE</b>	
<b>7. BASIC TIME PRICE (TOTAL OF 5-A AND 6)</b>	<b>3,000.00</b>
<b>8. TIME PRICE DIFFERENTIAL</b>	<b>NONE</b>
<b>9. TIME BALANCE (TOTAL OF 7 AND 8)</b>	<b>3,000.00</b>
<b>10. TIME SALE PRICE (TOTAL OF 2 AND 9)</b>	<b>\$</b>

**PHYSICAL DAMAGE INSURANCE COVERAGE**

Physical damage insurance to said motor vehicle, as designated below, is to be purchased for term from date of delivery until expiration date of \_\_\_\_\_, 19\_\_\_\_. (Check proper coverage).

- If a commercial motor vehicle, insure for fire, theft, combined additional coverage and \$\_\_\_\_\_ deductible collision and upset. Such insurance shall be based upon the principal usage of said vehicle(s) as checked below, including insurance upon other equipment described as \_\_\_\_\_ of the value of \$\_\_\_\_\_ to be attached to said vehicle(s) by the purchaser.
- Tractor type motor vehicle  Local hauling (under 50 miles)  Intermediate hauling (50 to 150 miles)  Long distance hauling (over 150 miles)  Hauling explosives, flammable liquids or gases  Logging and forestry operations, hauling logs, stumps, pulpwood, wholesale lumber.
- If a motor vehicle defined for insurance purposes as a private passenger vehicle, then for  Comprehensive (includes fire, theft, and combined additional coverage)  Fire, theft and combined additional coverage  \$\_\_\_\_\_ deductible collision and upset.  Towing and labor costs.
- Such (private passenger) vehicle insurance shall be based on collision classification as determined from rating statement.

**11. TERMS OF PAYMENT:** Purchaser agrees to pay the Time Balance in **1** instalments of \$ **3,000.00** each, and **---** instalments of \$ **-----** each, and **---** instalments of \$ **-----** each, and **---** instalments of \$ **-----**, payable on the same day of each successive month, commencing **November 29**, 19 **67**, and as follows **or before**.

at the office of the seller, or if this contract is assigned, assignee of the seller. After maturity each instalment shall draw interest at the rate of \_\_\_\_\_ percent per annum. Purchaser agrees to pay all expenses including reasonable attorney's fees, court costs, and out-of-pocket expenses incurred in the collection, by suit or otherwise, of any amount payable under this contract. Purchaser agrees to pay a delinquency and collection charge upon any instalment in default for a period of 10 days or more of 5% of the amount of the instalments in default, or the sum of \$5.00, whichever is the lesser.

If a charge is included in item 6 above for Group Creditor Life Insurance it is understood that Group Creditor Life Insurance is requested in connection with this contract and the purchaser signing on the first and uppermost line is the insured and hereby acknowledges receipt of Notice of Proposed Group Creditor Life Insurance.

Liability insurance coverage for bodily injury and property damage caused to others is NOT included herein.

Purchaser agrees that this contract, including the additional provisions printed on the reverse side hereof, which he has read and to which he agrees, contains the entire agreement relating to the instalment sale of said property and supersedes all previous contracts and agreements between purchaser and seller relating to the order or sale of said property. This contract is not binding upon seller, unless signed by the Manager of seller, or owner.

**NOTICE TO RETAIL BUYER:** Do not sign this contract in blank. You are entitled to a copy of the contract at the time you sign. Keep it to protect your legal rights. PURCHASER ACKNOWLEDGES RECEIPT OF AN EXACT COPY OF THIS CONTRACT.

APPROVED FOR SELLER		PRINT OR TYPE NAMES BENEATH SIGNATURES. ALL SIGNATURES MUST BE WITNESSED.			
SIGNATURE		SELLER	<b>International Harvester</b>	PURCHASER	<b>George A. Phelps</b>
OFFICIAL TITLE		BY	<b>Dr. Mgr.</b>	BY <b>X</b>	TITLE
		WITNESS		PURCHASER	<b>Rita Phelps</b>
		WITNESS		BY <b>X</b>	TITLE
	<b>Branch Manager</b>				



TELEPHONE 358-6010

GENE CHOQUETTE

SALESMAN  
INTERNATIONAL HARVESTER COMPANY  
1000 GLENDALE AVENUE, SPARKS (EAST RENO), NEVADA

STATE OF NEVADA  
DEPARTMENT OF MOTOR VEHICLES—REGISTRATION DIVISION  
DEALER'S REPORT OF SALE

IMPORTANT—Check New or Used Sale →  New  Used

Full Cash List Price

If USED vehicle, does it have Nevada registration? Yes  No

\$ 4018.00

**A 193120**

Use this form to report all vehicle sales including autos, trucks, trailers and motorcycles.

Attach same as a temporary permit to inside of windshield. The vehicle can then be operated for five (5) days from date of purchase, when it is impossible to secure registration.

Year 67 Make John Deere Body Type Tractor  
Model No. 1100B 4X4 No. of cyls 8

IMPORTANT Serial or ID No. 7531074735990-7 must be correct.

Required for Commercial vehicles: Motive power \_\_\_\_\_ Axles \_\_\_\_\_ Unladen weight \_\_\_\_\_

Date of purchase 11 24 67 Residence County of Washoe  
Month Day Year

PLEASE PRINT Name sold to GEORGE ALBERT PHILIPS Registered owner's name

Residence address 7091 Belmont

City Sparks State Nev

Legal owner Belmont Fed Emp Fed Cr Union

NOTICE: Legal owner's name will be shown on the title certificate as shown above.

Mailing address 689 Brandon City Sparks

County Washoe State Nev

Dealer's name INTERNATIONAL HARVESTER CO. Dealer's No. 10167

Address P.O. Box 1450  
Sparks, Nevada  
Salesman's name Gene Choquette Salesman's No. 1587

# TRAVELER'S RECEIPT

CUSTOMER'S NAME AND ADDRESS

GEORGE A. PHELPS

ACCOUNT NUMBER

542-3363 F.N.B.

CHECK NO. AND DATE	NAME OF BANK	(PAYEE IF ANY)	AMOUNT
IN FULL PAYMENT FOR ONE			\$
NEW TRAVELER # 735990			

## CURRENCY

APPLICATION	TOTAL COLLECTIONS
	\$3000 <sup>00</sup>

S	NOTE NUMBER	PRINCIPAL	INTEREST	COMBINED
E				\$
T				
O				
N	LESS-REFUND OF FINANCE			
TOTAL NET ON NOTE				\$3000 <sup>00</sup>

S	INVOICE NUMBER	AMOUNT
E		\$
T		
O		
N		
C		
E		
S		
TOTAL ON INVOICES		

TOTAL APPLICATION	\$3000 <sup>00</sup>
-------------------	----------------------

RECEIVED-INTERNATIONAL HARVESTER CO.	DISTRICT OFFICE	DATE
BY <i>Gene Ch... OK</i>		11/30/47
CUSTOMER		

FH-246



*Gene Choquette, the Ultimate Salesman, 1997*



*Gene Choquette & George Phelps, with '67 Travelall in 1997*



*Rita & George Phelps, with their 1967 Travelall in 1997*







1967 Travelall in 2006

